

MODULHARD'ANDREA

Bit-holders for
double-bit items

Plattenhalter für
Zweischneiderwerkzeuge

Кассеты для двухрезцовых
расточных головок

Noże do głowic
dwunożowych

Seggi per bitaglianti

SSCC

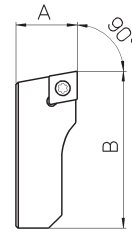

REF.	CODE	Ø ₁	A	B				kg
SSCC 16	47 050 05 16 201	18 ~ 22	8	15	CCMT 0602..	TS 25	TORX T08	0.003
SSCC 20	47 050 05 20 201	22 ~ 28	9.5	19				0.006
SSCC 25	47 050 05 25 201	28 ~ 38	12.5	23				0.01
SSCC 32	47 050 05 32 201	35.5 ~ 50	15	32				0.02
SSCC 33	47 050 05 32 204				CCMT 09T3..	TS 4	TORX T15	0.025
SSCC 40	47 050 05 40 201	50 ~ 68	19	40				0.06
SSCC 41	47 050 05 40 204				CCMT 1204..	TS 5	TORX T25	0.06
SSCC 50	47 050 05 50 204	68 ~ 90	22	54				0.1
SSCC 63	47 050 05 63 201	90 ~ 120	27	70.5				0.2
SSCC 80	47 050 05 80 201	120 ~ 160	32	94.5	0.5			
SSCC 90	47 050 05 90 201	160 ~ 800		130	0.7			

SMCC

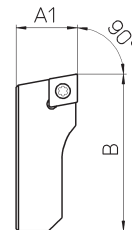

REF.	CODE	Ø ₁	A ₁	B				kg
SMCC 25	47 050 05 25 203	28 ~ 38	12.3	23	CCMT 0602..	TS 25	TORX T08	0.01
SMCC 32	47 050 05 32 203	35.5 ~ 50	14.8	32				0.02
SMCC 33	47 050 05 32 205				CCMT 09T3..	TS 4	TORX T15	0.025
SMCC 40	47 050 05 40 203	50 ~ 68	18.7	40				0.06
SMCC 41	47 050 05 40 205				CCMT 1204..	TS 5	TORX T25	0.06
SMCC 50	47 050 05 50 205	68 ~ 90	21.7	54				0.1
SMCC 63	47 050 05 63 203	90 ~ 120	26.7	70.5				0.2
SMCC 80	47 050 05 80 203	120 ~ 160	31.7	94.5	0.5			
SMCC 90	47 050 05 90 203	160 ~ 800		130	0.7			

p. 258

p. 218-219

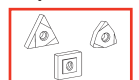

Bit-holders for
double-bit items

Plattenhalter für
Zweischneiderwerkzeuge



Кассеты для двухрезцовых
расточных головок

Noże do głowic
dwunożowych

Seggi per bitaglianti

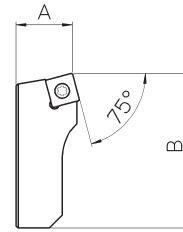

SSSC

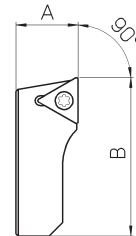

REF.	CODE	Ø ₁	A	B				kg
SSSC 32	47 050 05 32 202	35.5 ~ 50	15	32	SCMT 09T3..	TS 4	TORX T15	0.02
SSSC 40	47 050 05 40 202	50 ~ 68	19	40				0.06
SSSC 50	47 050 05 50 202	68 ~ 90	22	54	SCMT 1204..	TS 5	TORX T25	0.1
SSSC 63	47 050 05 63 202	90 ~ 120	27	70.5				0.2
SSSC 80	47 050 05 80 202	120 ~ 160	32	94.5				0.5
SSSC 90	47 050 05 90 202	160 ~ 800		130				0.7

SSTC



REF.	CODE	Ø ₁	A	B				kg
SSTC 63	47 050 05 63 206	90 ~ 120	27	70.5	TCMT 2204..	TS 5	TORX T25	0.2
SSTC 80	47 050 05 80 206	120 ~ 160	32	94.5				0.5
SSTC 90	47 050 05 90 206	160 ~ 800		130				0.7

p. 218-219

p. 258

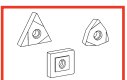

MODULHARD'ANDREA

Bit-holders for
double-bit items

Plattenhalter für
Zweischneiderwerkzeuge

Кассеты для двухрезцовых
расточных головок

Noże do głowic
dwunożowych

Seggi per bitaglianti

SSSM

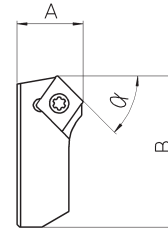

REF.	CODE	α	\varnothing_1	A	B				kg
SSSM 25	47 050 05 25 211	15°	26 ~ 38	12.5	23	CCMT 0602..	TS 25	TORX T08	0.01
	47 050 05 25 213	30°							
	47 050 05 25 215	45°							
SSSM 32	47 050 05 32 211	15°	34.5 ~ 49	15	31	CCMT 0602..	TS 25	TORX T08	0.025
	47 050 05 32 213	30°							
	47 050 05 32 215	45°							
SSSM 40	47 050 05 40 211	15°	46.5 ~ 66	19	39	CCMT 09T3..	TS 4	TORX T15	0.06
	47 050 05 40 213	30°							
	47 050 05 40 215	45°							
SSSM 50	47 050 05 50 211	15°	65 ~ 88	22	53	CCMT 1204..	TS 5	TORX T25	0.1
	47 050 05 50 213	30°							
	47 050 05 50 215	45°							

SSQC

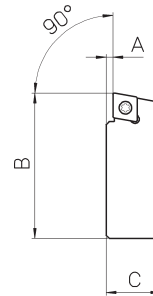

REF.	CODE	\varnothing_1	A	B	C				kg
SSQC 16	47 050 05 16 261	20 ~ 24	2	16	10	CCMT 0602..	TS 25	TORX T08	0.005
SSQC 20	47 050 05 20 261	23.5 ~ 30	1.5	19.5	11				0.008
SSQC 25	47 050 05 25 261	29.5 ~ 40	2.5	24	14.5				0.02
SSQC 33	47 050 05 33 261	39 ~ 52	3	32	17	CCMT 09T3..	TS 4	TORX T15	0.03
SSQC 41	47 050 05 41 261	51 ~ 70	3.5	42	21	CCMT 1204..	TS 5	TORX T25	0.08
SSQC 50	47 050 05 50 261	69 ~ 92		57	24.5				0.15
SSQC 63	47 050 05 63 261	91 ~ 122		76	28.5				0.3
SSQC 80	47 050 05 80 261	121 ~ 162		101	31.5				0.6
SSQC 90	47 050 05 90 261	161 ~ 802		122					0.8

p. 258

p. 218-219

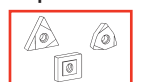

Counterweight

Gegengewicht

Противовес

Przeciwwaga

Contrappeso

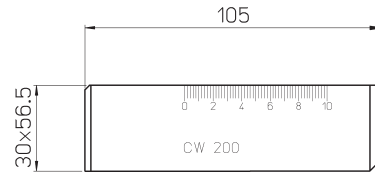
CW 200

REF.	CODE	kg
CW 200	39 20 110 105 01	1.3

Extensions

Verlängerungen

Удлинитель

Przedłużki

Prolunghe

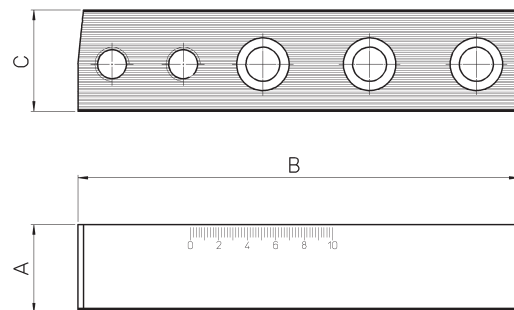
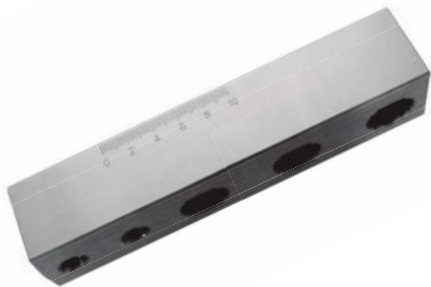
PRL 100 - 300

REF.	CODE	A	B	C	kg
PRL 100	39 20 110 155 01	31	155	35.5	1.1
PRL 300	39 20 110 300 01	41	255		2.8



MODULHARD'ANDREA

Bit-holders for
double-bit Testarossa

Testarossa mit
beidseitiger Schneide



Кассеты для двухкассетных
головок Testarossa

Noże do głowic
dwunożowych Testarossa

Seggi per Testarossa
Bitagliente

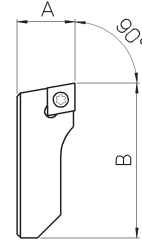

SSCC D

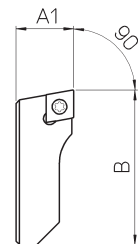

REF.	CODE	\varnothing_1	A	B				kg
SSCC 25 D	47 050 05 25 220	28 ~ 36	10	24	CCMT 0602..	TS 25	TORX T08	0.008
SSCC 32 D	47 050 05 32 220	36 ~ 46	11.5	30				0.015
SSCC 40 D	47 050 05 40 220	46 ~ 60	14	40	CCMT 09T3..	TS 4	TORX T15	0.03
SSCC 50 D	47 050 05 50 220	60 ~ 75	19	54				0.06
SSCC 63 D	47 050 05 63 220	75 ~ 95	24.5	68				0.15
SSCC 80 D	47 050 05 80 220	95 ~ 120	29.5	87				0.3

SFCC D



REF.	CODE	\varnothing_1	A ₁	B				kg
SFCC 25 D	47 050 05 25 020	28 ~ 36	9.8	24	CCGT 0602..	TS 25	TORX T08	0.008
SFCC 32 D	47 050 05 32 020	36 ~ 46	11.3	30				0.015
SFCC 40 D	47 050 05 40 020	46 ~ 60	13.8	40	CCGT 09T3..	TS 4	TORX T15	0.03
SFCC 50 D	47 050 05 50 020	60 ~ 75	18.8	54				0.06
SFCC 63 D	47 050 05 63 020	75 ~ 95	24.3	68				0.15
SFCC 80 D	47 050 05 80 020	95 ~ 120	29.3	87				0.3

p. 259

p. 218-219

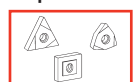

Bit-holders for
double-bit Testarossa

Testarossa mit
beidseitiger Schneide



Кассеты для двухкассетных
головок Testarossa

Noże do głowic
dwunożowych Testarossa

Seggi per Testarossa
Bitagliente

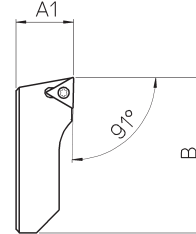
SFTP D



REF.	CODE	Ø1	A1	B				kg
SFTP 25 D	47 050 05 25 030	28 ~ 36	9.8	24	TPGX 0902..	CS 250T	TORX T08	0.008
SFTP 32 D	47 050 05 32 030	36 ~ 46	11.3	30				0.015
SFTP 40 D	47 050 05 40 030	46 ~ 60	13.8	40	TPGX 1103..	CS 300890T		0.03
SFTP 50 D	47 050 05 50 030	60 ~ 75	18.8	54				0.06
SFTP 63 D	47 050 05 63 030	75 ~ 95	24.3	68				0.15
SFTP 80 D	47 050 05 80 030	95 ~ 120	29.3	87				0.3

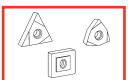

MODULHARD'ANDREA

Tools and
toolholders for
Testarossa

Werkzeuge und
Grundhalter für
Testarossa

Инструмент и оправки
для наборов Testarossa

Narzędzia i imaki
narzędziowe dla
Testarossa

Utensili e
portautensili per
Testarossa

P20.30

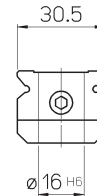
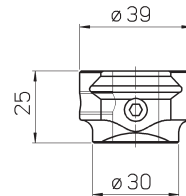

REF.	CODE	kg
P20.30	43 10 30 16 030 0	0.2

B1...

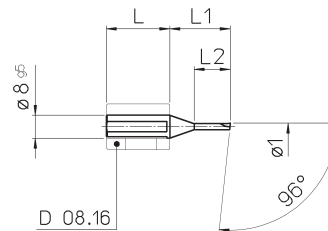

Carbide tools	Bohrstange aus Hartmetall	Твердосплавный инструмент	Narzędzia z węglika	Utensili in metallo duro		
REF.	CODE	Ø ₁	L	L ₁	L ₂	kg
B1.02	57 201 05 02 001	2.5 ~ 4	22	21	12.5	0.02
B1.04	57 201 05 04 001	4 ~ 6	24	24	—	

p. 260



p. 248



p. 237

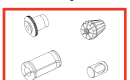

B1...

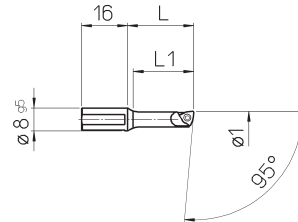

Tools	Bohrstange	Инструмент			Narzędzia		Utensili		kg
REF.	CODE	Ø ₁	L	L ₁					
B1.06	57 201 05 06 000	6 ~ 8	23	21	WCGT 0201..	-	TS 21	TORX T06	0.01
B1.08	57 201 05 08 000	8 ~ 10	28	-			TS 211		0.015
B1.10	57 201 05 10 000	10 ~ 12	36	-	-	TPGX 0902..	CS 250 T	TORX T08	0.02

B1...

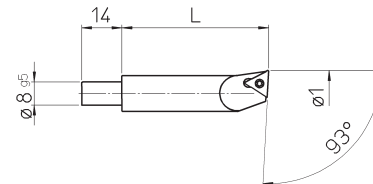

Tools	Bohrstange	Инструмент		Narzędzia		Utensili		kg
REF.	CODE	Ø ₁	L					
B1.12	57 201 05 12 000	12 ~ 14	42	TPGX 0902..	CS 250 T	TORX T08	0.03	
B1.14	57 201 05 14 000	14 ~ 16	48				0.04	
B1.16	57 201 05 16 000	16 ~ 18	54				0.05	



MODULHARD'ANDREA

Tools and
toolholders for
Testarossa

Werkzeuge und
Grundhalter für
Testarossa

Инструмент и оправки
для наборов Testarossa

Narzędzia i imaki
narzędziowe dla
Testarossa

Utensili e
portautensili per
Testarossa

B3...

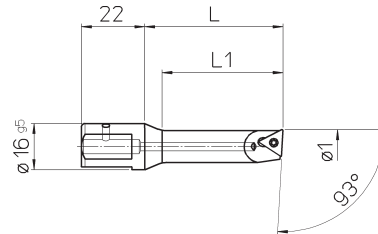

Tools	Bohrstange	Инструмент			Narzędzia			Utensili	
REF.	CODE	Ø ₁	L	L ₁					kg
B3.06	57 201 05 06 001	6 ~ 8	29	21	WCGT 0201..	-	TS 21	TORX T06	0.035
B3.08	57 201 05 08 001	8 ~ 10	36	28			TS 211		0.04
B3.10	57 201 05 10 001	10 ~ 12	43	35	-	TPGX 0902..	CS 250 T	TORX T08	0.05
B3.11	57 201 05 11 001	11 ~ 13	48	40					0.055
B3.12	57 201 05 12 001	12 ~ 14		42					0.06
B3.14	57 201 05 14 001	14 ~ 16	52	50					0.07
B3.16	57 201 05 16 001	16 ~ 18							58
B3.18	57 201 05 18 001	18 ~ 22	63	-					0.1
B3.22	57 201 05 22 001	22 ~ 30	68		0.1				

B5...

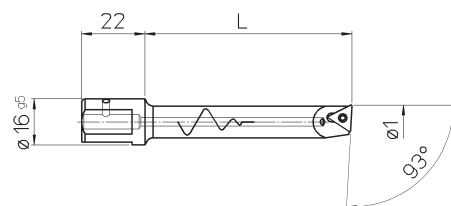

Vibration-damping tools	Vibrationsarme Bohrstangen	Виброгасящие оправки			Narzędzia antywibracyjne			Utensili antivibranti	
REF.	CODE	Ø ₁	L						kg
B5.06	57 201 05 06 105	6 ~ 8	36	WCGT 0201..	-	TS 21	TORX T06	0.075	
B5.08	57 201 05 08 105	8 ~ 10	48			TS 211		0.09	
B5.10	57 201 05 10 105	10 ~ 12	60	-	TPGX 0902..	CS 250 T	TORX T08	0.1	
B5.12	57 201 05 12 105	12 ~ 14	72					0.2	
B5.14	57 201 05 14 105	14 ~ 16	84					0.2	
B5.16	57 201 05 16 105	16 ~ 18	96					0.3	

p. 260

p. 218-219



Tools and
toolholders for
Testarossa

Werkzeuge und
Grundhalter für
Testarossa

Инструмент и оправки
для наборов Testarossa

Narzędzia z
trzonkiem
pełnowęglkowym

Utensili e
portautensili per
Testarossa

B8...

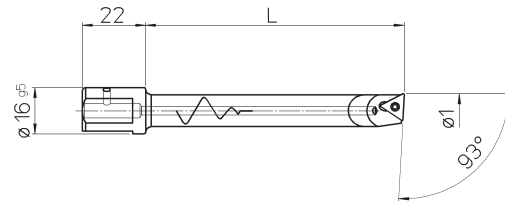

Tools with carbide
shank

Bohrstangen mit
Hartmetallschaft

Твердосплавные
оправки

Narzędzia z
trzonkiem
pełnowęglkowym

Utensili con stelo
in metallo duro

REF.	CODE	Ø ₁	L					kg
B8.06	57 201 05 06 108	6 ~ 8	45	WCGT 0201..	-	TS 21	TORX T06	0.065
B8.08	57 201 05 08 108	8 ~ 10	60			TS 211		0.08
B8.10	57 201 05 10 108	10 ~ 12	75	-	TPGX 0902..	CS 250 T	TORX T08	0.1
B8.12	57 201 05 12 108	12 ~ 14	90					0.2
B8.14	57 201 05 14 108	14 ~ 16	105					0.3
B8.16	57 201 05 16 108	16 ~ 18	120					

K20.50

Ø 6 ~ 30



K 20.50

- 1 B3.06
- 1 B3.08
- 1 B3.11
- 1 B3.16
- 1 B3.22
- 5 TPGX090202L
- 3 WCGT020102L

REF.	CODE	Ø
K20.50	65 50 001 0020 0	6 ~ 30

p. 218-219

p. 260



MODULHARD'ANDREA

Tools and
toolholders for
Testarossa

Werkzeuge und
Grundhalter für
Testarossa

Инструмент и оправки
для наборов Testarossa

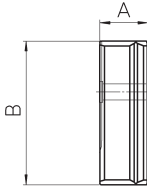
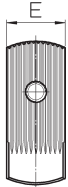

Narzędzia i imaki
narzędziowe dla
Testarossa

Utensili e
portautensili per
Testarossa

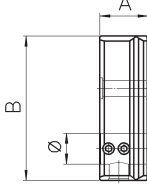
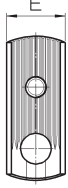
						PS ..
REF.	CODE	A	B	E	kg	
PS 11.30	43 30 30 26 075 0	25	75	30.5	0.4	
PS 12.30	43 30 30 26 095 0		93		0.5	
PS 13.30	43 30 30 26 140 0		135		0.7	
PS 11.40	43 30 40 35 150 0	40	133	40	1.5	
PS 12.40	43 30 40 35 230 0		200		2.4	
PS 13.40	43 30 40 35 330 0		300		3.5	
PS 14.40	43 30 40 35 400 0		400		4.6	

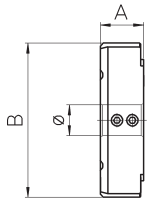
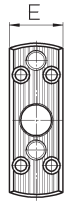
						PS 11.30 D.16
REF.	CODE	Ø H6	A	B	E	kg
PS 11.30 D.16	43 30 30 26 075 5	16	25	75	30.5	0.4

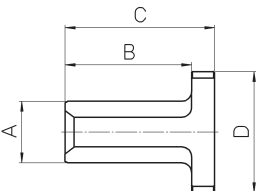
						PS ..
REF.	CODE	Ø H6	A	B	E	kg
PS 31.24	43 30 24 14 075 1	—	14.5	75	24	0.2
PS 31.28	43 30 28 22 080 1	16	22.5	80	28	0.3
PS 32.28	43 30 28 22 108 1	—		108		0.5
PS 33.28	43 30 28 22 148 1	—		148		0.6

						P 22.28	
REF.	CODE	A	B	C	D	E	kg
P 22.28	43 30 28 22 063 1	32	66	78	63	28	0.45



Tools and
toolholders for
Testarossa

Werkzeuge und
Grundhalter für
Testarossa

Инструмент и оправки
для наборов Testarossa

Narzędzia i imaki
narzędziowe dla
Testarossa

Utensili e
portautensili per
Testarossa

P 25....

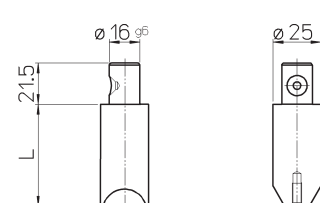
REF.	CODE	L	kg
P25.63	43 51 16 25 063 0	53	0.5
P25.105	43 51 16 25 105 0	95	0.8

P0..

REF.	CODE	A	B	C	D	E	kg.
P02.30	43 10 30 25 040 0	25	40	52.5	43	30.5	0.3
P03.30	43 10 30 25 070 0	25	70	82.5			0.4
P04.30	43 10 30 25 115 0	27	115	127.5			0.7
P02.40	43 10 40 32 070 0	32	69	86	56	40	0.7
P03.40	43 10 40 32 115 0	32	114	131			1
P04.40	43 10 40 32 190 0	38	189	206			2

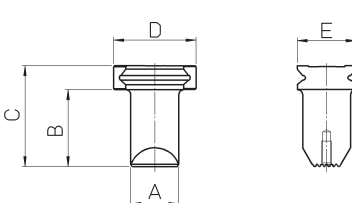
Blocking
bit-holder sleeve

Sitzblockierungsbuchse

Стопор

Tuleja blokująca nóż

Bussola
bloccaggio seggio

BM 10



REF.	CODE	kg
BM 10	20 104 10 150 02	0.02

Counterweight

Gegengewicht

Противовес

Przeciwwaga

Contrappeso

CW 32

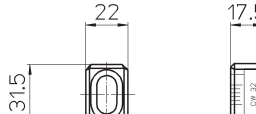
REF.	CODE	kg
CW 32	39 20 110 032 01	0.5



MODULHARD'ANDREA

Bit-holders for
Testarossa

Plattenhalter für
Testarossa

Кассеты для
Testarossa

Nože dla Testarossa

Seggi per
Testarossa

SFWC

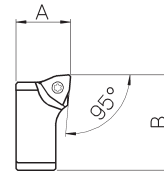

REF.	CODE	Ø ₁	A	B				kg.
SFWC 14	47 050 05 14 002	14.5 ~ 18	8	14	WCGT 0201..	TS 211	TORX T06	0.003

SFTP

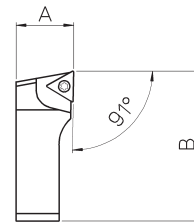

REF.	CODE	Ø ₁	A	B				kg.
SFTP 25	47 050 05 25 001	28 ~ 40	10	26.5	TPGX 0902..	CS 250T	TORX T08	0.01
SFTP 32	47 050 05 32 001	35 ~ 53	11.5	34.5				0.02
SFTP 40	47 050 05 40 001	48 ~ 66	14	44	TPGX 1103..	CS 300890T		0.04
SFTP 50	47 050 05 50 001	54 ~ 800	19	52				0.08

SFCC

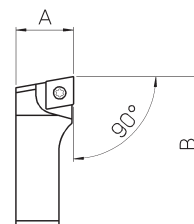

REF.	CODE	Ø ₁	A	B				kg.
SFCC 16	47 050 05 16 002	18 ~ 24	8	17	CCGT 0602..	TS 25	TORX T08	0.003
SFCC 20	47 050 05 20 002	22 ~ 30	8.5	21				0.005
SFCC 25	47 050 05 25 002	28 ~ 40	10	26.5				0.01
SFCC 32	47 050 05 32 002	35 ~ 53	11.5	34.5				0.02
SFCC 40	47 050 05 40 002	48 ~ 66	14	44	CCGT 09T3..	TS 4	TORX T15	0.04
SFCC 50	47 050 05 50 002	54 ~ 800	19	52				0.08

p. 260

p. 218-219

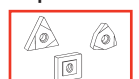

Bit-holders for
Testarossa

Plattenthaler für
Testarossa



Кассеты для
Testarossa

Nože dla Testarossa

Seggi per
Testarossa

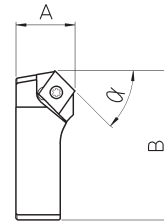
SFSM





REF.	CODE	α	\varnothing_1	A	B				kg.
SFSM 25	47 050 05 25 011	15°	28 ~ 40	10	25.5	CCMT 0602..	TS 25	TORX T08	0.01
	47 050 05 25 013	30°							
	47 050 05 25 015	45°							
SFSM 32	47 050 05 32 011	15°	35 ~ 53	11.5	33.5	CCMT 0602..	TS 25	TORX T08	0.02
	47 050 05 32 013	30°							
	47 050 05 32 015	45°							
SFSM 40	47 050 05 40 011	15°	48 ~ 66	14	42.5	CCMT 09T3..	TS 4	TORX T15	0.03
	47 050 05 40 013	30°							
	47 050 05 40 015	45°							
SFSM 50	47 050 05 50 011	15°	54 ~ 800	19	50.5	CCMT 09T3..	TS 4	TORX T15	0.07
	47 050 05 50 013	30°							
	47 050 05 50 015	45°							

189

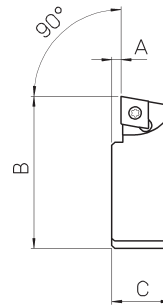
SFQC



REF.	CODE	\varnothing_1	A	B	C				kg.
SFQC 16	47 050 05 16 062	20 ~ 26	2	18	10	CCMT 0602..	TS 25	TORX T08	0.005
SFQC 20	47 050 05 20 062	24.5 ~ 33		22.5	10.5				0.008
SFQC 25	47 050 05 25 062	31.5 ~ 42	2.5	28.5	12				0.01
SFQC 32	47 050 05 32 062	39 ~ 55		35.5	13.5	0.03			
SFQC 40	47 050 05 40 062	51 ~ 68	3	46	16.5	CCMT 09T3..	TS 4	TORX T15	0.06
SFQC 50	47 050 05 50 062	56 ~ 802		53	20.5				0.1

p. 218-219

p. 260

