

KINTEK

MANDRINI DOPPIO CONTATTO **DK**
DOUBLE CONTACT TOOLHOLDER **DK**

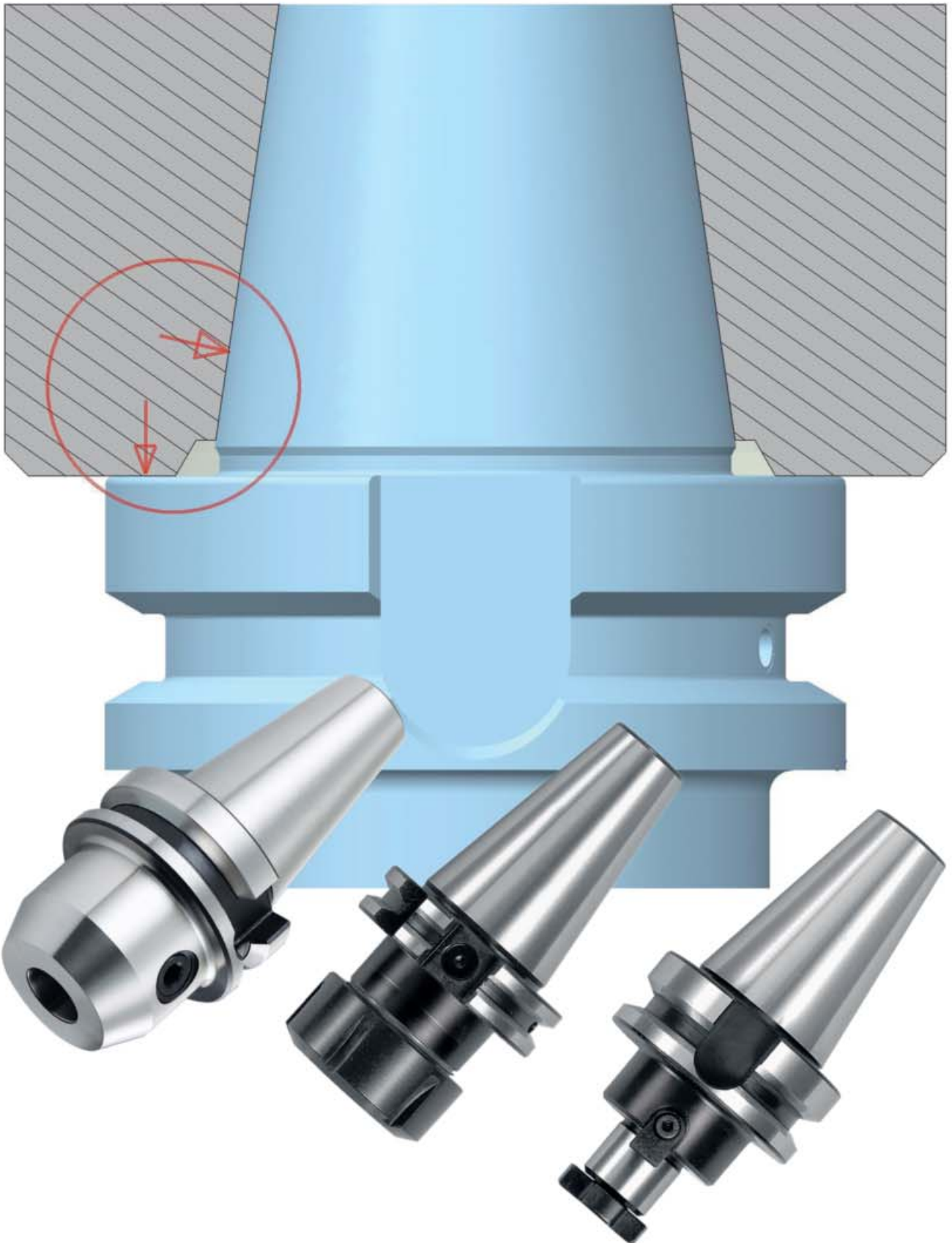



Die zahlreichen Vorzüge des DK:

- Dank einer erhöhten fit Durchmesser Steifigkeit Verbesserung
- Drastische Verbesserung des ATC Wiederholbarkeit
- Verhinderung der Verschiebung in der Z-Achse
- Verbesserung der Lebensdauer der Schneidwerkzeug
- Verhinderung von Passungsrost
- Verbesserung und Stabilität der Bearbeitungsgenauigkeit und bearbeiteten Oberfläche



The numerous merits of double contact toolholder DK:

- Rigidity improvement thanks to an increased fit diameter
- Drastic improvement of the ATC repeatability
- Prevention of displacement in the Z-axis
- Improvement of the life of the cutting tool
- Prevention of fretting corrosion
- Improvement and stability of the machining accuracy and machined surface



Многочисленные достоинства DK:

- Улучшение жесткости благодаря увеличению диаметра подходят
- Резкое улучшение повторяемости УВД
- Предотвращение смещения в Z-оси
- Улучшение жизни режущего инструмента
- Предотвращение фреттинг коррозии
- Улучшение и стабильность точности обработки обрабатываемой поверхности и



Les nombreux mérites de DK:

- Amélioration de la rigidité grâce à un diamètre ajustement accuré.
- Amélioration drastique de la répétabilité ATC
- Prévention de déplacement sur l'axe Z
- L'amélioration de la durée de vie de l'outil de coupe
- Prévention de la corrosion de contact
- L'amélioration de la stabilité et la précision d'usinage et la surface usinée



I numerosi meriti del mandrino doppio contatto DK:

- Miglioramento rigidità grazie ad un diametro aumentato fit
- Drastico miglioramento della ripetibilità ATC
- Prevenzione dello spostamento in Z
- Miglioramento della vita dell'utensile di taglio
- Prevenzione della corrosione da contatto
- Miglioramento e stabilità della precisione di lavorazione e superficie lavorata



DK 刀夹:

- 剛性的改善得益於精確的配合直徑
- 空管重複性的大幅改善
- 預防Z軸位移
- 切削工具的壽命的改進
- 預防接觸面腐蝕
- 改善加工精度和加工表面的穩定性

DOPPELKONTAKT AUFNAHMEN ER SPANNZANGENFUTTER
DOUBLE CONTACT ER COLLET CHUCK
ЦАНГОВЫЙ ПАТРОН ER С ДВОЙНЫМ КОНТАКТОМ

MADRINS DOUBLE CONTACT PORTE-PINCE ER
MANDRINI PORTAPINZA A DOPPIO CONTATTO TIPO ER
ER双向夹头

MAS 403/BT AD/B

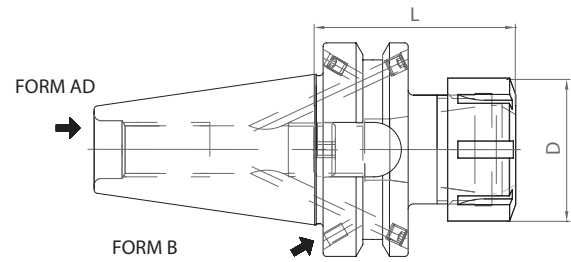

Code N.	Description	ISO	ER	D	L	G6,3 15000 RPM
214-37201	BT30H70ER16 AD	30	16	32	70	•
214-37202	BT30H70ER20 AD	30	20	35	70	•
214-37203	BT30H70ER25 AD	30	25	42	70	•
214-37204	BT30H70ER32 AD	30	32	50	70	•
214-37205	BT40H70ER16 AD+B	40	16	32	70	•
214-37206	BT40H70ER25 AD+B	40	25	42	70	•
214-37207	BT40H70ER32 AD+B	40	32	50	70	•
214-37208	BT40H70ER40 AD+B	40	40	63	70	•
214-37209	BT40H100ER16 AD+B	40	16	32	100	•
214-37210	BT40H100ER25 AD+B	40	25	42	100	•
214-37211	BT40H100ER32 AD+B	40	32	50	100	•
214-37212	BT40H100ER40 AD+B	40	40	63	100	•
214-37213	BT50H80ER32 AD+B	50	32	50	80	•
214-37214	BT50H80ER40 AD+B	50	40	63	80	•
214-37215	BT50H100ER32 AD+B	50	32	50	100	•
214-37216	BT50H100ER40 AD+B	50	40	63	100	•
214-37217	BT50H160ER32 AD+B	50	32	50	160	•
214-37218	BT50H200ER32 AD+B	50	32	50	200	•

DOPPELKONTAKT AUFNAHMEN ER SPANNZANGENFUTTER
DOUBLE CONTACT ER COLLET CHUCK
ЦАНГОВЫЙ ПАТРОН ER С ДВОЙНЫМ КОНТАКТОМ

MADRINS DOUBLE CONTACT PORTE-PINCE ER
MANDRINI PORTAPINZA A DOPPIO CONTATTO TIPO ER
ER双向夹头

DIN 69871 AD/B

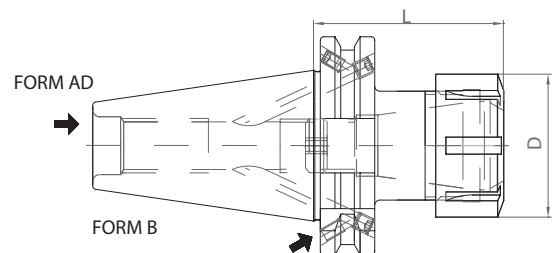

Code N.	Description	ISO	ER	D	L	G6,3 15000 RPM
214-37101	TC40H70ER16 AD+B	40	16	32	70	•
214-37102	TC40H70ER25 AD+B	40	25	42	70	•
214-37103	TC40H70ER32 AD+B	40	32	50	70	•
214-37104	TC40H70ER40 AD+B	40	40	63	70	•
214-37105	TC40H100ER16 AD+B	40	16	32	100	•
214-37106	TC40H100ER25 AD+B	40	25	42	100	•
214-37107	TC40H100ER32 AD+B	40	32	50	100	•
214-37108	TC40H100ER40 AD+B	40	40	63	100	•

DOPPELKONTAKT AUFNAHMEN AUFSTÄCKFRÄSDORNE
DOUBLE CONTACT FACE MILL HOLDERS-TENONS DRIVE
ОПРАВКИ ДЛЯ НАСАДНЫХ ФРЕЗ С ДВОЙНЫМ КОНТАКТОМ

MADRINS DOUBLE CONTACT PORTE-FRAISE
MANDRINI PORTAFRESE A DOPPIO CONTATTO A TRASCINAMENTO FISSO
双向铣刀柄

MAS 403/BT AD/B

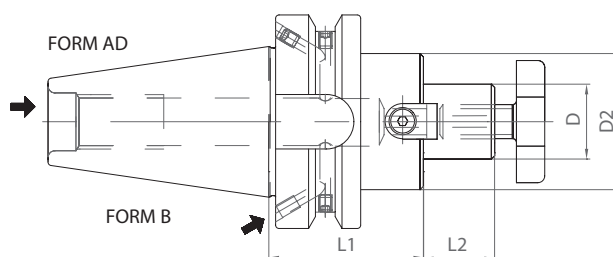

Code N.	Description	ISO	D	L1	L2	D2	G6,3 12000 RPM
216-77201	BT30H45D22F AD	30	22	45	19	48	•
216-77202	BT30H45D27F AD	30	27	45	21	60	•
216-77203	BT40H45D22F AD+B	40	22	45	19	48	•
216-77204	BT40H60D22F AD+B	40	22	60	19	48	•
216-77205	BT40H45D27F AD+B	40	27	45	21	60	•
216-77206	BT40H60D27F AD+B	40	27	60	21	60	•

DOPPELKONTAKT AUFNAHMEN AUFSTÄCKFRÄSDORNE
DOUBLE CONTACT FACE MILL HOLDERS-TENONS DRIVE
ОПРАВКИ ДЛЯ НАСАДНЫХ ФРЕЗ С ДВОЙНЫМ КОНТАКТОМ

MADRINS DOUBLE CONTACT PORTE-FRAISE
MANDRINI PORTAFRESE A DOPPIO CONTATTO A TRASCINAMENTO FISSO
双向铣刀柄

DIN 69871 AD/B

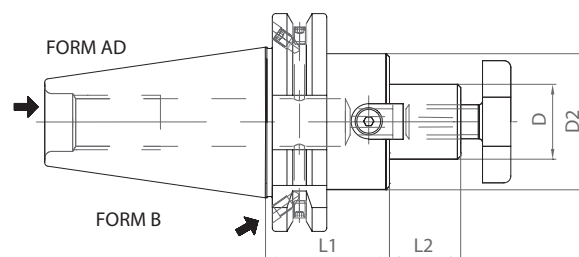

Code N.	Description	ISO	D	L1	L2	D2	G6,3 12000 RPM
216-77101	TC40H35D22F AD+B	40	22	35	19	48	•
216-77102	TC40H60D27F AD+B	40	27	60	21	58	•

DOPPELKONTAKT AUFNAHMEN WELDON
 DOUBLE CONTACT END MILL HOLDERS WELDON
 ОПРАВКИ С КРЕПЛЕНИЕМ WELDON С ДВОЙНЫМ КОНТАКТОМ

MADRINS DOUBLE CONTACT WELDON
 MANDRINI PORTAFRESE A DOPPIO CONTATTO TIPO WELDON
 WELDON双向铣刀柄

MAS 403/BT AD/B

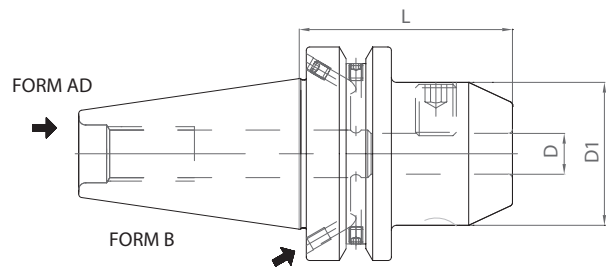

Code N.	Description	ISO	D	L	D1	G6,3 15000 RPM
213-17225	BT30H60WE06 AD	30	6	60	25	•
213-17226	BT30H60WE08 AD	30	8	60	28	•
213-17227	BT30H60WE10 AD	30	10	60	35	•
213-17228	BT30H60WE12 AD	30	12	60	42	•
213-17229	BT30H75WE16 AD	30	16	75	48	•
213-17230	BT30H75WE20 AD	30	20	75	52	•
213-17231	BT30H90WE25 AD	30	25	90	65	•
213-17232	BT40H50WE06 AD+B	40	6	50	25	•
213-17233	BT40H50WE08 AD+B	40	8	50	28	•
213-17234	BT40H63WE10 AD+B	40	10	63	35	•
213-17235	BT40H63WE12 AD+B	40	12	63	42	•
213-17236	BT40H63WE16 AD+B	40	16	63	48	•
213-17237	BT40H63WE18 AD+B	40	18	63	50	•
213-17238	BT40H63WE20 AD+B	40	20	63	52	•
213-17239	BT40H100WE25 AD+B	40	25	100	65	•
213-17240	BT40H100WE32 AD+B	40	32	100	72	•

DOPPELKONTAKT AUFNAHMEN WELDON
 DOUBLE CONTACT END MILL HOLDERS WELDON
 ОПРАВКИ С КРЕПЛЕНИЕМ WELDON С ДВОЙНЫМ КОНТАКТОМ

MADRINS DOUBLE CONTACT WELDON
 MANDRINI PORTAFRESE A DOPPIO CONTATTO TIPO WELDON
 WELDON双向铣刀柄

DIN 69871 AD/B

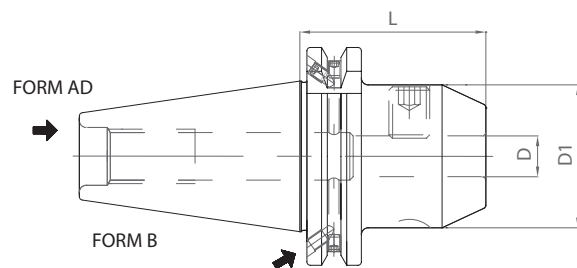

Code N.	Description	ISO	D	L	D1	G6,3 15000 RPM
213-17113	TC40H50WE06 AD+B	40	6	50	25	•
213-17114	TC40H50WE08 AD+B	40	8	50	28	•
213-17115	TC40H50WE10 AD+B	40	10	50	35	•
213-17116	TC40H50WE12 AD+B	40	12	50	42	•
213-17117	TC40H63WE16 AD+B	40	16	63	48	•
213-17118	TC40H63WE18 AD+B	40	18	63	50	•
213-17119	TC40H63WE20 AD+B	40	20	63	52	•
213-17120	TC40H100WE25 AD+B	40	25	100	65	•
213-17121	TC40H100WE32 AD+B	40	32	100	72	•

DOPPELKONTAKT AUFNAHMEN SCHRUMPFUTTER
CONTACT SHRINK FIT CHUCKS
ТЕРМОЗАЖИМНЫЕ ПАТРОНЫ С ДВОЙНЫМ КОНТАКТОМ

MADRINS DOUBLE CONTACT DE FRETAGE
MANDRINI A DOPPIO CONTATTO A CALETTAMENTO
双向热缩刀柄

MAS 403/BT AD/B

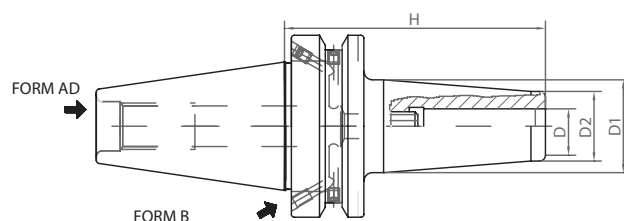
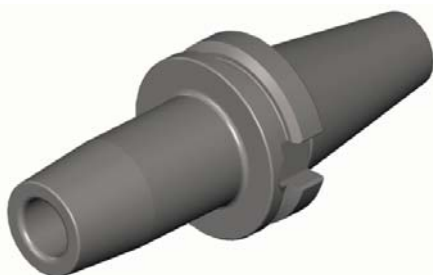

Code N.	Description	ISO	D	H	D1	D2	G2,5 25000 RPM
251-17201	BT40H90K06-HTT	40	6	90	26	21	•
251-17202	BT40H90K08-HTT	40	8	90	26	21	•
251-17203	BT40H90K10-HTT	40	10	90	29	24	•
251-17204	BT40H90K12-HTT	40	12	90	29	24	•
251-17205	BT40H90K16-HTT	40	16	90	32	27	•
251-17206	BT40H100K20-HTT	40	20	100	38	33	•
251-17207	BT40H100K25-HTT	40	25	100	49	44	•
251-17208	BT40H100K32-HTT	40	32	100	49	44	•

DOPPELKONTAKT AUFNAHMEN SCHRUMPFUTTER
DOUBLE CONTACT SHRINK FIT CHUCKS
ТЕРМОЗАЖИМНЫЕ ПАТРОНЫ С ДВОЙНЫМ КОНТАКТОМ

MADRINS DOUBLE CONTACT DE FRETAGE
MANDRINI A DOPPIO CONTATTO A CALETTAMENTO
双向热缩刀柄

DIN 69871 AD/B

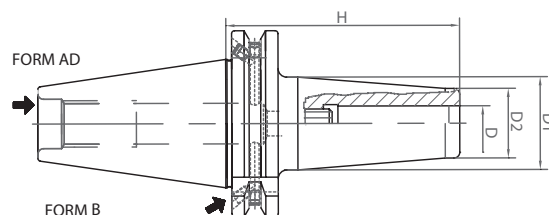

Code N.	Description	ISO	D	H	D1	D2	G2,5 25000 RPM
251-17101	TC40H80K06-HTT	40	6	80	26	21	•
251-17102	TC40H80K08-HTT	40	8	80	26	21	•
251-17103	TC40H80K10-HTT	40	10	80	29	24	•
251-17104	TC40H80K12-HTT	40	12	80	29	24	•
251-17105	TC40H80K16-HTT	40	16	80	32	27	•
251-17106	TC40H90K20-HTT	40	20	90	38	33	•
251-17107	TC40H100K25-HTT	40	25	100	49	44	•
251-17108	TC40H100K32-HTT	40	32	100	49	44	•



VIA GORETTA 88/G - 10072 MAPPANO
FRAZIONE DI CASELLE (TO) - ITALIA
Tel. +39.011.9968065 - Fax +39.011.9965662
<http://www.kintek.it> - e-mail: info@kintek.it